



## Kvaser Air Bridge M12 User's Guide



Copyright 2024-2024 Kvaser AB, Mölndal, Sweden  
<https://www.kvaser.com>

Printed Wednesday 22<sup>nd</sup> May, 2024

We believe that the information contained herein was accurate in all respects at the time of printing. Kvaser AB cannot, however, assume any responsibility for errors or omissions in this text. Also note that the information in this document is subject to change without notice and should not be construed as a commitment by Kvaser AB.

(This page is intentionally left blank.)

## Contents

|          |  |           |
|----------|--|-----------|
| <b>1</b> | <b>About this manual</b>                     | <b>4</b>  |
| <b>2</b> | <b>Introduction</b>                          | <b>5</b>  |
| 2.1      | Welcome to Kvaser Air Bridge M12 . . . . .   | 6         |
| 2.2      | Major Features . . . . .                     | 8         |
| <b>3</b> | <b>Kvaser Air Bridge M12 hardware</b>        | <b>9</b>  |
| 3.1      | Hardware installation . . . . .              | 9         |
| 3.2      | CAN channel . . . . .                        | 10        |
| 3.3      | Power supply . . . . .                       | 10        |
| 3.4      | LED Indicators . . . . .                     | 10        |
| 3.5      | Technical data . . . . .                     | 11        |
| 3.6      | CAN Connectors . . . . .                     | 12        |
| 3.7      | CAN bus termination . . . . .                | 13        |
| 3.8      | Autobaud Detection . . . . .                 | 13        |
| 3.9      | Commissioning . . . . .                      | 14        |
| 3.10     | Pairing . . . . .                            | 15        |
| <b>4</b> | <b>Appendices</b>                            | <b>16</b> |
| 4.1      | Kvaser Air Bridge Utility CLI . . . . .      | 16        |
| <b>5</b> | <b>Safety Instructions</b>                   | <b>18</b> |
| 5.1      | Intended Use . . . . .                       | 18        |
| 5.2      | Usage Warning . . . . .                      | 18        |
| <b>6</b> | <b>Disposal and Recycling Information</b>    | <b>20</b> |
| <b>7</b> | <b>Legal acknowledgements</b>                | <b>22</b> |
| 7.1      | EU Regulatory Compliance . . . . .           | 22        |
| 7.2      | FCC Regulatory Compliance . . . . .          | 23        |
| 7.3      | Patents, Copyrights and Trademarks . . . . . | 24        |
| <b>8</b> | <b>Document Revision History</b>             | <b>25</b> |

## 1 About this manual

This manual is intended for Kvaser Air Bridge M12 users. This document contains a description of the hardware's properties and general instructions on how to use the Kvaser Air Bridge M12.

Three complementary documents are available:

- Kvaser Air Bridge Installation Guide
- Kvaser Air Bridge System Integration Guide
- Kvaser Air Bridge Management Interface description

The Kvaser Air Bridge Installation Guide provides installation advice for end-users who use Kvaser Air Bridge and want to optimize radio performance and reach.

The Kvaser Air Bridge System Integration Guide provides design-in advice for system integrators who use Kvaser Air Bridge as a system component and want to make the most of its data bridging capability, not least in scenarios where multiple Kvaser Air Bridge devices are to be employed.

The Kvaser Air Bridge Management Interface description provides information about the Kvaser Air Bridge's Management Interface. The Kvaser Air Bridge Management Interface is an application-level request/response protocol that enables a user application to access the control- and monitoring services of a Kvaser Air Bridge device.

## 2 Introduction

This section describes the functions and features of the single Kvaser Air Bridge M12 'one-to-any' wireless CAN device.

The Kvaser Air Bridge M12 is the latest addition to the Kvaser Air Bridge product family consisting of the following product variants:

| Device                               | Product Number   |
|--------------------------------------|------------------|
| Kvaser Air Bridge Light HS           | 73-30130-00808-3 |
| Kvaser Air Bridge Light HS (FCC)     | 73-30130-01008-6 |
| Kvaser Air Bridge Light HS M12       | 73-30130-01141-0 |
| Kvaser Air Bridge Light HS M12 (FCC) | 73-30130-01148-9 |
| Kvaser Air Bridge M12                | 73-30130-01494-7 |

Table 1: Kvaser Air Bridge devices and their EAN numbers.

The (00808-3 and 01141-0) Kvaser Air Bridge Light HS is approved for the European Union, while (01008-6 and 01148-9) Kvaser Air Bridge Light HS (FCC) is optimized for the US. They both share the same functionality but have different radio transmitting schemes due to regulatory differences. The (01494-7) Kvaser Air Bridge M12 M12 is approved for both the European Union and the US.

Note: all Kvaser Air Bridge devices marked with an FCC ID are approved for use in the US.

Whereas the Kvaser Air Bridge Light HS comes in a pair of pre-configured devices, the Kvaser Air Bridge M12 is designed as a single, multi-role device meaning that it can take on the role of Master unit or Slave unit (a 'one to any' configuration). This is an advantage from a logistics perspective where a damaged device can be easily replaced. This also means that a user can freely commission a set of Kvaser Air Bridge M12 devices that better suit the operational needs of the system e.g. where one control station needs to connect to more than one remote apparatus.

A Kvaser Air Bridge M12 device commissioned as Master Unit can thereby be paired freely with any Kvaser Air Bridge M12 device commissioned as Slave unit. The role of a Kvaser Air Bridge M12 device can also be changed at any time during operation. This is controlled by the application by using specialized commands over the CAN bus.

Compared to Kvaser Air Bridge Light HS, the Kvaser Air Bridge M12 is not only a more advanced product from a networking perspective, but it also enables configuration of certain operational parameters to adapt to and optimise Kvaser Air Bridge for the user's system.

The Kvaser Air Bridge Utility CLI facilitates the maintenance of the Kvaser Air Bridge by supporting firmware release update, see Section 4.1, Kvaser Air Bridge Utility CLI, on Page 16 for more information. Configuration of certain parameters is

also available via the Management Interface which can be made available using special CAN messages with a specific format. The Kvaser Air Bridge Utility CLI can be downloaded from Kvaser's web site.

To aid readability, the name Kvaser Air Bridge is hereinafter used to refer to the Kvaser Air Bridge product in general. The name Kvaser Air Bridge M12 is used to refer to the specific product and NOT the product in general.

## 2.1 Welcome to Kvaser Air Bridge M12



Figure 1: Kvaser Air Bridge M12

Kvaser Air Bridge M12 is a single and small, yet advanced, wireless CAN device that can be used to form a CAN system bridge between two CAN networks.

This radio solution can be used to connect CAN based control systems and test

equipment in scenarios and situations where it is desirable to replace cabling and related parts.

The Kvaser Air Bridge M12 is designed for ease-of use, while retaining a certain flexibility for the user by means of configuration; choose between 'one to one', or 'one to any'. The Kvaser Air Bridge Utility CLI enables a user to commission Kvaser Air Bridge M12 devices in a simple and straight-forward fashion.

This guide applies to Kvaser Air Bridge M12 devices listed in Table 2.

| <b>Device</b>         | <b>Product Number</b> |
|-----------------------|-----------------------|
| Kvaser Air Bridge M12 | 73-30130-01494-7      |

Table 2: Kvaser Air Bridge M12 devices and their EAN numbers.

## 2.2 Major Features

- Forms a wireless CAN bridge between two Kvaser Air Bridge devices.
- Can be paired with any other Kvaser Air Bridge M12 device.
- Supports both 11-bit (CAN 2.0A) and 29-bit (CAN 2.0B active) and identifiers.
- High-Speed CAN connection (compliant with ISO 11898-2), up to 1 Mbit/s.
- Compatible with J1939, CANopen, NMEA 2000<sup>®</sup> and DeviceNet. Higher layer protocol translation is handled by the user's application. For software support please see our Technical Associates products and our Software Download page ([www.kvaser.com](http://www.kvaser.com)).
- Driver-free and only limited configuration required.
- Provides configuration flexibility to support a wide variety of application requirements.
- Pairing, configuration and link status via management protocol over the CAN bus.
- Active discovery feature that detects available Kvaser Air Bridge M12 devices for pairing.
- Point-to-point radio link.
- Proprietary wireless protocol provides robust, low latency connection in an instant.
- Internal antenna design with polarization diversity.
- Power supplied through the CAN bus connector.
- User configurable bit rates (125k, 250k, 500k and 1M).
- Automatic bit rate detection or user configured.
- Bit rate conversion between CAN bus systems with different bit rates.
- IP65-rated, dust and water-resistant, aluminium housing.
- IP67-rated M12 connector for cabling with extra dust and water-tightness, suitable for outdoor installation.
- Extended operating temperature range.



## 3 Kvaser Air Bridge M12 hardware

In this section you can read more about the CAN channel, power supply and LED indicators.

### 3.1 Hardware installation

The Kvaser Air Bridge M12 is a wireless CAN device that can be used together with another Kvaser Air Bridge M12 to form a CAN bridge. A Kvaser Air Bridge M12 device can thereby be paired with any other Kvaser Air Bridge M12, i.e. 'one-to-any', thereby forming a pair of Kvaser Air Bridge M12 units. Although not a Kvaser Air Bridge Light HS, which is sold as one of a pair of preconfigured CAN bridge units, the Kvaser Air Bridge M12 can also be preconfigured as a pair of units and as such it will only need to be configured once.

The advantage of using a Kvaser Air Bridge M12, as opposed to a preconfigured Kvaser Air Bridge Light HS, is that it provides options to freely pair and unpair Kvaser Air Bridge M12 units and to alter the operational settings to better suit the specific system characteristics and user application. All Kvaser Air Bridge devices are designed to coexist with each other.

The Kvaser Air Bridge M12 is driver free, with only limited configuration needed, which is simple using the Kvaser Air Bridge Utility CLI. Pairing can be performed during commissioning, although it is primarily intended to be controlled from a host application by means of special messages on the CAN bus defined in the Management Interface. Once paired, the two Kvaser Air Bridge M12 devices need just be connected to their CAN segments, nothing else is required!

When connected to a CAN bus system, the Kvaser Air Bridge M12 device will by default determine the bit rate used by the attached CAN system using Automatic Baud Rate Detection (autobaud), see Section 3.8, Autobaud Detection, on Page 13. Once the autobaud detection has completed successfully, the devices will transmit CAN messages back and forth until they are powered down. Note: The autobaud feature can be overridden to speed up connection time, by selecting one of four supported bit rates. As the Kvaser Air Bridge protocol provides an internal bit rate conversion scheme, the bit rates may be chosen independently for every Kvaser Air Bridge M12 device. Bit rate selection is done within the Kvaser Air Bridge Utility CLI or via the Management Interface.

A Kvaser Air Bridge device will only forward CAN messages between the two attached CAN networks. Error frames and arbitration information will not be forwarded since this information is only applicable for the local physical network. The recommended minimum distance between two Kvaser Air Bridge devices is 0.5 m.

### 3.2 CAN channel

The Kvaser Air Bridge M12 has one CAN Hi-Speed channel with a 5-pin M12 Male CAN connector. See Section 3.6, CAN Connectors, on Page 12 for details about the pinout.



Figure 2: M12 5-pole Male CAN connector

### 3.3 Power supply

The Kvaser Air Bridge M12 is powered through the CAN connector. To operate the Kvaser Air Bridge M12, you **must** supply 9-36 VDC power through the CAN connector.

### 3.4 LED Indicators

The functions of the LED indicators on the Kvaser Air Bridge M12 are shown in Table 3 on Page 11.



Figure 3: LEDs on the Kvaser Air Bridge M12.

| LED           | Description   |
|---------------|---|
| CAN (Yellow)  | CAN channel status, indicate received and sent messages.                          |
| RF (Blue)     | Radio Link status, indicate received radio packets and signal strength.           |
| POWER (Green) | Power indicates that the unit has been powered on and baud rates are established. |

Table 3: LEDs on the Kvaser Air Bridge M12.



Before power is indicated, the LEDs briefly perform an LED test, indicate states related to the establishment of the radio link and indicate state of the autobaud detection.

### 3.5 Technical data

In Table 4 below you will find the Kvaser Air Bridge M12's technical specifications. The physical dimensions are given in Figure 4 on Page 12.

|   |  |
|---|--|
| CAN Channels                                    | 1  |
| CAN Transceivers                                | TJA1051T (Compliant with ISO 11898-2)  |
| CAN Controller                                  | Built into the processor   |
| CAN Bit Rate                                    | 1 Mbit/s, 500 Kbit/s, 250 Kbit/s, and 125 Kbit/s                                     |
| Autobaud <sup>1</sup>                           | Yes  |
| Message Rate, CAN 2.0A (11-bit ID) <sup>2</sup> | 2x2100 messages/s  |
| Message Rate, CAN 2.0B (29-bit ID) <sup>2</sup> | 2x1680 messages/s  |
| Message transfer capacity <sup>3</sup>          | Corresponding to 100% bus load for both directions at 250 kbit/s bit rate            |
| Message Latency                                 | Typically 2.5-7.5 ms   |
| Connection time from power up                   | Normally less than 1 s   |
| Reconnection time                               | Normally less than 200 ms  |
| Configuration                                   | Tx power, CAN bit rate   |
| Wireless Communication                          | Frequency Hopping Spread Spectrum (FHSS) with Gaussian Frequency-Shift Keying (GFSK) |
| Spectrum (FHSS) modulation                      |  |
| Frequency Range                                 | 2400 MHz to 2483.5 MHz (2.4 GHz band)  |
| Antenna Output Power                            | Max 18 dBm   |
| Power Supply                                    | 9-36 VDC   |
| Power Consumption                               | Typically 2 W  |
| Current Consumption (at 9 VDC)                  | Typically 220 mA   |
| Weight  | 85 g   |
| IP Rating Housing                               | IP65   |
| IP Rating CAN connector                         | IP67 Mated   |
| Operating Temperature                           | -40 °C to +70 °C   |

Table 4: Technical Specifications.

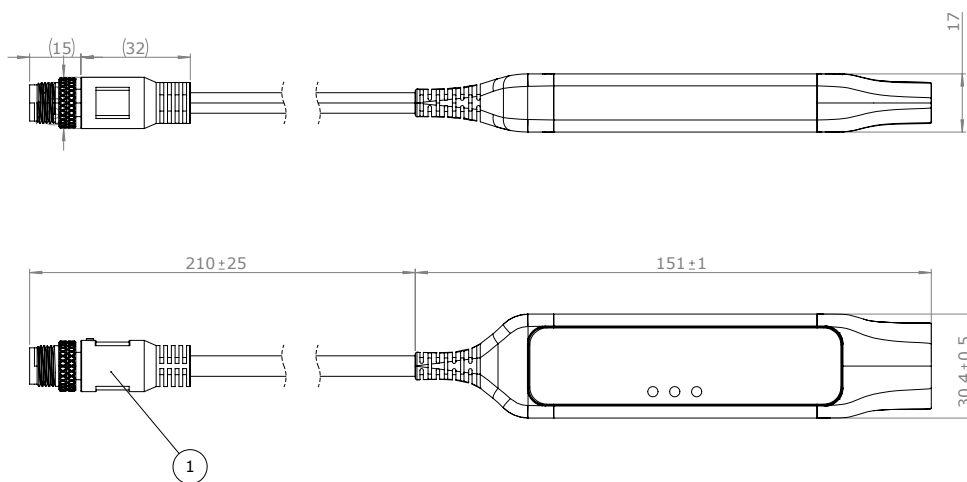

Figure 4: Physical dimensions of the Kvaser Air Bridge M12

### 3.6 CAN Connectors

Kvaser Air Bridge M12 devices that use the 5-pole male M12 connector have the pinning described in Table 5 on Page 13.

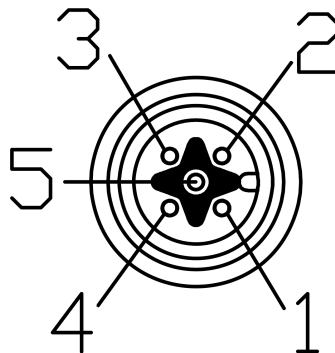

Figure 5: 5-pole male M12 Connector

<sup>1</sup>Automatic establishment upon start-up. Refer to Section 3.8, Autobaud Detection, on Page 13 for more information.

<sup>2</sup>Maximum message rate in both directions for eight byte payload. Refer to "Kvaser Air Bridge System Integration Guide" for more information.

<sup>3</sup>Recommended maximum load is 80%. Refer to "Kvaser Air Bridge System Integration Guide" for more information.

| M12 pin number | Function                   |
|----------------|----------------------------|
| 1              | Shield                     |
| 2              | Power supply to the device |
| 3              | GND                        |
| 4              | CAN_H                      |
| 5              | CAN_L                      |

Table 5: 5-pole M12 pin configuration

### 3.7 CAN bus termination

Every CAN bus must be terminated with a 120 Ohm resistor at each end of the bus. The Kvaser Air Bridge M12 does not contain any CAN bus termination, because their inclusion could cause severe disturbance in a system which is already correctly terminated.

For laboratory or testing use, the exact value of the termination resistors is not always critical. Sometimes a single terminator is sufficient. For production, proper termination is essential. If you see error frames on the bus, you should check the termination.



**To save yourself a lot of trouble, always terminate the CAN bus properly.**

### 3.8 Autobaud Detection

The Kvaser Air Bridge M12 provides an Autobaud Detection feature which will automatically detect and connect to any of the following CAN network bit rates:

- 1 Mbit/s
- 500 Kbit/s
- 250 Kbit/s
- 125 Kbit/s.

The Autobaud Detection is done locally, so a Kvaser Air Bridge M12 can be used to bridge two different CAN networks operating at different bit rates. However, the amount of traffic on the networks will determine whether the system designer should allow the networks to be bridged via the Kvaser Air Bridge M12.



Autobaud is the process of automatically selecting the correct bus parameters for communication on the connected CAN bus based on received CAN traffic. The Autobaud Detection is driven by the reception of CAN messages on the CAN network. This means that there needs to be existing CAN traffic on the network for the Autobaud Detection to work.

If, after 15 seconds of power on, only one of the paired units have done a successful Autobaud Detection, the other unit will be configured to the same CAN network bit rate. The Autobaud Detection will continue even after 15 seconds, if none of the supported CAN system bit rates have been detected on either of the connected CAN networks.



If the Kvaser Air Bridge M12 is used to bridge two different CAN networks operating at different bit rates, both CAN networks needs to send messages during the initial 15 seconds after power on in order for the Autobaud Detection to correctly detect the different bit rates.

For any additional/specific bit rate requirement, please contact Kvaser for more info.

### 3.9 Commissioning

The Kvaser Air Bridge M12 builds on a role-based hierarchy to provide synchronization and pairing of Kvaser Air Bridge M12 devices. All Kvaser Air Bridge M12 devices have the possibility of assuming on of two roles, i.e. acting as a Master unit or a Slave unit. By default, all Kvaser Air Bridge M12 devices are configured to be Slave units.

Before being put into service, the Kvaser Air Bridge M12 devices need to be commissioned as either Master units or Slave units. Kvaser provides a Utility CLI for this purpose. The Utility CLI allows customer specific domain keys to be entered to prevent unwanted interference from Kvaser Air Bridge M12 devices operated by other organizations. However, all Kvaser Air Bridge M12 devices are delivered with default keys that work perfectly well should the user choose not to define the domain key.

In conjunction with the commissioning, a user can also choose to change the following ones of the default operational parameters should the application require adaptation to specific characteristics:

- Bit rate
- Pairing
- Retransmission
- Transmit power

Note that some of the parameters are non-volatile.

Note also that all the settings that are available through the Kvaser Air Bridge Utility CLI are also accessible via the Management Interface and can therefore be configured by any user application developed for that purpose.

More information can be found in the Kvaser Air Bridge Management Interface description.

### 3.10 Pairing

A Kvaser Air Bridge M12 device commissioned as Master unit can be paired with any Kvaser Air Bridge M12 device commissioned as Slave unit, if it is powered on and within radio coverage and hence can be discovered by the Kvaser Air Bridge M12 Master unit. Normally, this discovery and pairing is managed over the CAN bus using dedicated CAN messages. The Master unit starts by prompting all Slave units to report their presence while reporting all present Slave units and their unique identifiers (same as serial numbers) to the application (client). After a short time, the application can request that the Master unit is paired with a specific Slave unit, using its unique identifier.

A Kvaser Air Bridge M12 Master unit can also be paired with a preferred Slave unit without this being powered and within coverage. This pairing can be performed through the management protocol, but it is also possible to configure this via the Utility CLI.

More information can be found in the Kvaser Air Bridge Management Interface description.

## 4 Appendices

In this section you will find technical information about the Kvaser Air Bridge M12.

### 4.1 Kvaser Air Bridge Utility CLI

#### General

The Kvaser Air Bridge Utility CLI is a PC based tool to be employed by Kvaser Air Bridge M12 users for firmware update and commissioning of Kvaser Air Bridge M12 devices. The Kvaser Air Bridge Utility CLI contains all functionality for this purpose and the firmware distribution is embedded into the Kvaser Air Bridge Utility CLI.

The Kvaser Air Bridge Utility CLI is available on the Kvaser web site in the software area and can be installed on a regular Windows PC.

#### Installation

The installation should be performed as follows:

1. Install the Kvaser's SDK and Device guide driver, which can be downloaded from the Kvaser web site.
2. Copy the Kvaser Air Bridge Utility CLI file (`airbridge-utility-cli.exe`) to a file location according to own preference.

#### Preparations

The following are required to use the Kvaser Air Bridge Utility CLI:

- The Kvaser Air Bridge M12 devices to be commissioned.
- Any Kvaser interface (e.g. Leaf Light v2).
- CAN bus wiring that connects the Kvaser Interface with the Kvaser Air Bridge M12 and provides power to the latter.

Further preparation for commissioning is performed in the following steps:

1. Start the command window by clicking on the windows icon and type 'cmd' followed by ENTER.
2. Navigate to the preferred file location by using appropriate commands, e.g: `cd Downloads`
3. Check that the Utility CLI file (`airbridge-utility-cli.exe`) is in the location (example: `C:\Users\AirBridgeUser\Downloads`) with the `dir` command.



4. The installation can e.g. be checked with the following command:

```
File_location > airbridge-utility-cli.exe -h
```

The Utility CLI will then respond with a general explanation of commands and parameters.

## Commissioning

Prepare the physical installation as follows:

1. Connect the Kvaser interface (Leaf) securely to the Kvaser Air Bridge M12 unit, making sure that the units cannot be accidentally disconnected from each other.
2. Apply power to the Kvaser Air Bridge M12 - the unit will perform the start-up test lighting up each of the three LED:s and then ending with a lit green LED.

Perform the commissioning of Role and Key seeds according to the following:

1. Configure the device's role by one of the following commands followed by ENTER:

```
File_location > airbridge-utility-cli.exe -ch 0 -c -D -R -SRFR M
```

```
File_location > airbridge-utility-cli.exe -ch 0 -c -D -R -SRFR S
```

An 'M' will commission the device to the role Master unit whereas an 'S' will commission the device to the role Slave unit. The following "List Parameter" command can be used to check that the correct commissioning has been performed:

```
File_location > airbridge-utility-cli.exe -ch 0 -c -D -R -LP
```

2. Configure the device's key seeds by the following commands followed by ENTER:

```
File_location > airbridge-utility-cli.exe -ch 0 -c -D -R -Set_RF_Master_Seed xxxx
```

```
File_location > airbridge-utility-cli.exe -ch 0 -c -D -R -Set_RF_Master_Seed yyyy
```

Where 'xxxx' and 'yyyy' represent user specific seeds for the generation of keys to protect the discovery and pairing procedures.

Note: For confidentiality reasons, the Utility's response to the "List Parameter" command will never show the entered Key seeds.

## 5 Safety Instructions

### 5.1 Intended Use

The Kvaser Air Bridge M12 is intended for connection of two CAN bus segments in a fixed installation.

### 5.2 Usage Warning



CAUTION: THE SURFACE OF THIS DEVICE MAY BECOME HOT IF IT IS EXPOSED TO FOR EXAMPLE RADIATION FROM THE SUN.



### WARNING FOR ALL USERS

WARNING! - YOUR USE OF THIS DEVICE MUST BE DONE WITH CAUTION AND A FULL UNDERSTANDING OF THE RISKS!

THIS WARNING IS PRESENTED TO INFORM YOU THAT THE OPERATION OF THIS DEVICE MAY BE DANGEROUS. YOUR ACTIONS CAN INFLUENCE THE BEHAVIOR OF A CAN-BASED DISTRIBUTED EMBEDDED SYSTEM, AND DEPENDING ON THE APPLICATION, THE CONSEQUENCES OF YOUR IMPROPER ACTIONS COULD CAUSE SERIOUS OPERATIONAL MALFUNCTION, LOSS OF INFORMATION, DAMAGE TO EQUIPMENT, AND PHYSICAL INJURY TO YOURSELF AND OTHERS. A POTENTIALLY HAZARDOUS OPERATING CONDITION IS PRESENT WHEN THE FOLLOWING TWO CONDITIONS ARE CONCURRENTLY TRUE: THE PRODUCT IS PHYSICALLY INTERCONNECTED TO A REAL DISTRIBUTED EMBEDDED SYSTEM; AND THE FUNCTIONS AND OPERATIONS OF THE REAL DISTRIBUTED EMBEDDED SYSTEM ARE CONTROLLABLE OR INFLUENCED BY THE USE OF THE CAN NETWORK. A POTENTIALLY HAZARDOUS OPERATING CONDITION MAY RESULT FROM THE ACTIVITY OR NON-ACTIVITY OF SOME DISTRIBUTED EMBEDDED SYSTEM FUNCTIONS AND OPERATIONS, WHICH MAY RESULT IN SERIOUS PHYSICAL HARM OR DEATH OR CAUSE DAMAGE TO EQUIPMENT, DEVICES, OR THE SURROUNDING ENVIRONMENT.

WITH THIS DEVICE, YOU MAY POTENTIALLY:

- CAUSE A CHANGE IN THE OPERATION OF THE SYSTEM, MODULE, DEVICE, CIRCUIT, OR OUTPUT.
- TURN ON OR ACTIVATE A MODULE, DEVICE, CIRCUIT, OUTPUT, OR FUNCTION.
- TURN OFF OR DEACTIVATE A MODULE, DEVICE, CIRCUIT, OUTPUT, OR FUNCTION.
- INHIBIT, TURN OFF, OR DEACTIVATE NORMAL OPERATION.
- MODIFY THE BEHAVIOR OF A DISTRIBUTED PRODUCT.
- ACTIVATE AN UNINTENDED OPERATION.
- PLACE THE SYSTEM, MODULE, DEVICE, CIRCUIT, OR OUTPUT INTO AN UNINTENDED MODE.

ONLY THOSE PERSONS WHO:

(A) ARE PROPERLY TRAINED AND QUALIFIED WITH RESPECT TO THE USE OF THE DEVICE,

(B) UNDERSTAND THE WARNINGS ABOVE, AND

(C) UNDERSTAND HOW THIS DEVICE INTERACTS WITH AND IMPACTS THE FUNCTION AND SAFETY OF OTHER PRODUCTS IN A DISTRIBUTED SYSTEM AND THE APPLICATION FOR WHICH THIS DEVICE WILL BE APPLIED, MAY USE THE DEVICE.

PLEASE NOTE THAT YOU CAN INTEGRATE THIS PRODUCT AS A SUBSYSTEM INTO HIGHER-LEVEL SYSTEMS. IN CASE YOU DO SO, KVASER AB HEREBY DECLARES THAT KVASER AB'S WARRANTY SHALL BE LIMITED TO THE CORRECTION OF DEFECTS, AND KVASER AB HEREBY EXPRESSLY DISCLAIMS ANY LIABILITY OVER AND ABOVE THE REFUNDING OF THE PRICE PAID FOR THIS DEVICE, SINCE KVASER AB DOES NOT HAVE ANY INFLUENCE ON THE IMPLEMENTATIONS OF THE HIGHER-LEVEL SYSTEM, WHICH MAY BE DEFECTIVE.

## 6 Disposal and Recycling Information



When this product reaches its end of life, please dispose of it according to your local environmental laws and guidelines.

For information about Kvaser's recycling programs, visit:  
<https://www.kvaser.com/en/kvaser/recycling-policy.html>



## 7 Legal acknowledgements

### 7.1 EU Regulatory Compliance



#### EU Declaration of Conformity (DoC)

We

|                 |               |                   |                  |
|-----------------|---------------|-------------------|------------------|
| Company Name:   | Kvaser AB     | City:             | Mölndal          |
| Postal address: | Aminogatan 25 | Telephone number: | +46 31 886344    |
| Postcode:       | 431 53        | E-mail address:   | sales@kvaser.com |

declare that the DoC is issued under our sole responsibility and belongs to the following product:

Product: Kvaser Air Bridge M12

**Object of the declaration** (identification of apparatus allowing traceability):

Product: Kvaser Air Bridge M12

Type: 73-30130-01494-7

**The object of the declaration described above is in conformity with the relevant Union harmonisation legislation:**

Radio Equipment Directive (RED) 2014/53/EU (Art. 3.1a, 3.1b and 3.2)

RoHS recast Directive 2011/65/EU (Art. 4.1)

**The following harmonised standards and technical specifications have been applied**

(title, date of standard/specification):

|                                |                              |
|--------------------------------|------------------------------|
| EN 203 367 (2016-03 (1.1.0))   | EN 300 328 (2016-11 (2.1.1)) |
| EN 301 489-1 (2016-11 (2.1.1)) | EN 301 489-17 (2016 (3.1.1)) |
| EN 55032 (2015 + A11:2020)     | EN 62 368-1 (2014 + AC:2015) |
| EN 50581 (2012)                |                              |

Signed for and on behalf of:

Mölndal

2024-02-12

Place of issue

Date of issue

  
Kent Lennartsson, Research Manager

## 7.2 FCC Regulatory Compliance



Federal Communications Commission (FCC) Compliance Information Statement

**IDENTIFICATION OBJECT:**

Product: Kvaser Air Bridge M12

Type: 73-30130-01494-7

**APPLICABLE COMPLIANCE STATEMENTS:**

CFR Title 47 Part 15 §15.107, §15.109

This device complies with part 15 of the FCC Rules.

Operation is subject to the following two conditions:

- (1) This device may not cause harmful interference, and
- (2) this device must accept any interference received, including interference that may cause undesired operation.

**RESPONSIBLE PARTY (IN USA) NAME:**

Kvaser Inc.

23881 Via Fabricante, Suite 503

Mission Viejo, CA 92691

Internet contact: [support@kvaser.com](mailto:support@kvaser.com)

### 7.3 Patents, Copyrights and Trademarks

All trademarks are the property of their respective owner. Windows is a registered trademark of Microsoft Corporation in the United States and other countries.

Adobe, the Adobe logo, and Reader are either registered trademarks or trademarks of Adobe Systems Incorporated in the United States and/or other countries.

DeviceNet is a trademark of Open DeviceNet Vendor Association, Inc.

NMEA 2000 is the registered trademark of the National Marine Electronics Association, Inc.

For information about Kvaser related CAN patents, see [www.kvaser.com/patent](http://www.kvaser.com/patent).

The products described in this document are protected by U.S. patent 5,696,911.



## 8 Document Revision History

Version history for document UG\_98297\_air\_bridge\_m12:

| Revision | Date       | Changes   |
|----------|------------|---|
| 1.0      | 2024-02-12 | Initial version.  |
| 1.1      | 2024-05-07 | Updated Kvaser logo, pictures, the major features list and technical data table. Minor textual changes. |