



Kvaser Air Bridge M12 User's Guide



Copyright 2024-2024 Kvaser AB, Mölndal, Sweden
<https://www.kvaser.com>

Printed Wednesday 18th September, 2024

We believe that the information contained herein was accurate in all respects at the time of printing. Kvaser AB cannot, however, assume any responsibility for errors or omissions in this text. Also note that the information in this document is subject to change without notice and should not be construed as a commitment by Kvaser AB.

(This page is intentionally left blank.)

Contents

1	About this manual	4
2	Introduction	5
2.1	Welcome to Kvaser Air Bridge 'one-to-any'	5
2.2	Major Features	8
3	Kvaser Air Bridge M12 hardware	9
3.1	Hardware installation	9
3.2	CAN channel	10
3.3	Power supply	10
3.4	LED Indicators	10
3.5	Commissioning	11
3.6	Autobaud	12
3.7	Optional bit rate setting	13
3.8	Optional custom CAN configuration	13
3.9	CAN filters	14
3.10	Pairing	14
4	Appendices	15
4.1	Technical data	15
4.2	Physical dimensions	16
4.3	CAN Connectors	16
4.4	CAN bus termination	17
4.5	Kvaser Air Bridge Utility CLI	17
5	Safety Instructions	23
5.1	Intended Use	23
5.2	Usage Warning	23
6	Disposal and Recycling Information	25
7	Legal acknowledgements	27
7.1	EU Regulatory Compliance	27
7.2	FCC Regulatory Compliance	28
7.3	Patents, Copyrights and Trademarks	29
8	Document Revision History	30

1 About this manual

This manual is intended for Kvaser Air Bridge M12 users. It contains a description of the hardware's properties and general instructions on how to use the Kvaser Air Bridge M12.

Three complementary documents are available:

- Kvaser Air Bridge Installation Guide
- Kvaser Air Bridge System Integration Guide
- Kvaser Air Bridge Management Interface Description

The Kvaser Air Bridge Installation Guide provides installation advice for end-users who use Kvaser Air Bridge and want to optimize radio performance and reach. The Kvaser Air Bridge Installation Guide applies to all The Kvaser Air Bridge variants.

The Kvaser Air Bridge System Integration Guide provides design-in advice for system integrators who use Kvaser Air Bridge as a system component and want to make the most of its data bridging capability, not least in scenarios where multiple Kvaser Air Bridge devices are to be employed. The Kvaser Air Bridge System Integration Guide applies to all The Kvaser Air Bridge variants.

The Kvaser Air Bridge Management Interface Description provides information about the Kvaser Air Bridge's Management Interface. The Kvaser Air Bridge Management Interface is an application-level request/response protocol that enables a user application to access the control- and monitoring services of a Kvaser Air Bridge device. The Kvaser Air Bridge Management Interface Description applies to all The Kvaser Air Bridge variants.

2 Introduction

This section describes the functions and features of the single Kvaser Air Bridge M12 'one-to-any' wireless CAN device.

Whereas the Kvaser Air Bridge Light HS comes in a pair of pre-configured and statically paired devices, the Kvaser Air Bridge M12 is designed as a single, multi-role device meaning that it can take on the role of a Primary device or a Secondary device (in a 'one to any' configuration). This is an advantage from a logistics perspective where a damaged device can be easily replaced. This also means that a user can freely commission a set of Kvaser Air Bridge M12 devices that better suit the operational needs of the system e.g. where one control station needs to connect to more than one remote apparatus.

A Kvaser Air Bridge M12 device commissioned as Primary device can thereby be paired freely with any Kvaser Air Bridge M12 device commissioned as Secondary device. The role of a Kvaser Air Bridge M12 device can also be changed at any time during operation. This is controlled by the application by using specialized commands over the CAN bus.

Compared to Kvaser Air Bridge Light HS, the Kvaser Air Bridge M12 is not only a more advanced product from a networking perspective, but it also enables configuration of certain operational parameters to adapt to and optimize Kvaser Air Bridge for the user's system. A special Kvaser Air Bridge Utility CLI is available for that purpose and besides supporting upgrade to the latest firmware.

To aid readability, the name Kvaser Air Bridge is hereinafter used to refer to the Kvaser Air Bridge product in general. The name Kvaser Air Bridge Light is used to refer to any of the four Kvaser Air Bridge Light HS variants and the name Kvaser Air Bridge 'one-to-any' is used to refer to the more advanced Kvaser Air Bridge M12 variant.

2.1 Welcome to Kvaser Air Bridge 'one-to-any'

Kvaser Air Bridge 'one-to-any' is a single and small, yet advanced, wireless CAN device that can be used to form a CAN system bridge between two CAN bus segments. This radio solution can be used to connect CAN based control systems and test equipment in scenarios and situations where it is desirable to replace cabling and related parts, to connect to one out of many moving or rotating system components, to interface to systems in inaccessible areas or to ensure electrical isolation during maintenance of high voltage power lines.

The Kvaser Air Bridge 'one-to-any' is designed for ease-of use, while retaining a certain flexibility for the user by means of configuration; choose between 'one to one', or 'one to any'. A special Kvaser Air Bridge Utility CLI is available that enables a user to commission Kvaser Air Bridge 'one-to-any' devices in a simple and straight-forward fashion through configuration of the very few basic settings that



Figure 1: Kvaser Air Bridge M12

may be subject to configuration by a user, e.g. their roles (Primary device or Secondary device) and CAN bus bit rate. Configuration of certain parameters is also available via the Management Interface which can be made available using special CAN messages with a specific format. The Kvaser Air Bridge Utility CLI can be downloaded from Kvaser's web site.

The Kvaser Air Bridge Utility CLI also facilitates the maintenance of the Kvaser Air Bridge by supporting firmware upgrade, see Section 4.5, Kvaser Air Bridge Utility CLI, on Page 17 for more information.

This guide applies to Kvaser Air Bridge M12 devices using at least the firmware versions listed in Table 1.

Device	Product Number	Firmware
Kvaser Air Bridge M12	73-30130-01494-7	2.4.0

Table 1: Firmware version needed to support all functionality present in this guide.

This guide applies to Kvaser Air Bridge M12 devices listed in Table 1.

2.2 Major Features

- Forms a wireless CAN bridge between two Kvaser Air Bridge devices.
- Can be paired with any other Kvaser Air Bridge 'one-to-any' device.
- Supports both 11-bit (CAN 2.0A) and 29-bit (CAN 2.0B active) and identifiers.
- High-Speed CAN connection (compliant with ISO 11898-2), up to 1 Mbit/s.
- Compatible with J1939, CANopen, NMEA 2000[®] and DeviceNet. Higher layer protocol translation is handled by the user's application. For software support please see our Technical Associates products and our Software Download page (www.kvaser.com).
- Driver-free and only limited configuration required.
- Provides configuration flexibility to support a wide variety of application requirements.
- Supports CAN filters (up to 4 pass filters based on CAN ID and mask).
- Pairing, configuration and link status via management protocol over the CAN bus.
- Active discovery feature that detects available Kvaser Air Bridge 'one-to-any' devices for pairing.
- Support for innovative applications based on user-controlled data that is transferred in the discovery process.
- Point-to-point radio link.
- Proprietary wireless protocol provides robust, low latency connection in an instant.
- Internal antenna design with polarization diversity.
- Power supplied through the CAN bus connector.
- User configurable bit rates (125k, 250k, 500k and 1M).
- Custom CAN configuration (Bit rate, Bit segments, Sync Jump Width and Silent mode).
- Automatic bit rate detection or user configured.
- Bit rate conversion between CAN bus systems with different bit rates.
- IP65-rated, dust and water-resistant, aluminium housing.
- IP67-rated M12 connector for cabling with extra dust and water-tightness, suitable for outdoor installation.
- Extended operating temperature range.

3 Kvaser Air Bridge M12 hardware

In this section you can read more about the CAN channel, power supply and LED indicators.

3.1 Hardware installation

The Kvaser Air Bridge 'one-to-any' is a wireless CAN device that can be used together with another Kvaser Air Bridge 'one-to-any' to form a CAN bridge. A Kvaser Air Bridge 'one-to-any' device can be paired with any other Kvaser Air Bridge 'one-to-any', thereby forming a pair of Kvaser Air Bridge 'one-to-any' devices. A Kvaser Air Bridge 'one-to-any' device cannot be paired with a Kvaser Air Bridge Light device, which is sold as a preconfigured pair of CAN bridge devices.

The advantage of using Kvaser Air Bridge 'one-to-any', as opposed to a preconfigured Kvaser Air Bridge Light, is that it provides options to freely pair and unpair Kvaser Air Bridge 'one-to-any' devices and to alter the operational settings to better suit the specific system characteristics and user application. All Kvaser Air Bridge devices are designed to coexist with each other.

The Kvaser Air Bridge 'one-to-any' is driver free, with only limited configuration needed, which is simple using the Kvaser Air Bridge Utility CLI. Pairing is controlled from a host application by means of special messages on the CAN bus defined in the Management Interface. Once paired, the two Kvaser Air Bridge 'one-to-any' devices need just be connected to their CAN segments, nothing else is required!

When connected to a CAN bus system, a Kvaser Air Bridge device will by default determine the bit rate used by the attached CAN system using Automatic Baud Rate Detection (autobaud), see Section 3.6, Autobaud, on Page 12. Once the autobaud detection has completed successfully, the devices will transmit CAN messages back and forth until they are powered down.

Note: The autobaud feature can be overridden to speed up connection time, by selecting one of four supported bit rates or by entering a Custom CAN configuration. As the Kvaser Air Bridge protocol provides an internal bit rate conversion scheme, the bit rates may be chosen independently for every Kvaser Air Bridge device. Selection of bit rate is done within the Kvaser Air Bridge Utility CLI or via the Management Interface (only Kvaser Air Bridge 'one-to-any'). The user specific Custom CAN configuration comprises Bit rate, Bit segment values, Sync Jump Width and Silent mode.

A Kvaser Air Bridge device will only forward CAN messages between the two attached CAN bus segments. Error frames and arbitration information will not be forwarded since this information is only applicable for the local physical network.

To limit the number of CAN messages transferred between the two CAN bus segments, the Kvaser Air Bridge 'one-to-any' supports user defined CAN bus filters.

The recommended minimum distance between two Kvaser Air Bridge devices is 0.5 m.

3.2 CAN channel

The Kvaser Air Bridge M12 has one CAN Hi-Speed channel with a 5-pin M12 Male CAN connector. See Section 4.3, CAN Connectors, on Page 16 for details about the pinout.



Figure 2: M12 5-pole Male CAN connector

3.3 Power supply

All Kvaser Air Bridge are powered through the CAN connector. To operate the Kvaser Air Bridge devices, you **must** supply 9-36 VDC power through the CAN connector.

3.4 LED Indicators

The functions of the LED indicators on the Kvaser Air Bridge 'one-to-any' are shown in Table 2.

LED	Description
CAN (Yellow)	CAN channel status, indicate received and sent messages.
RF (Blue)	Radio Link status, pairing activity, indicate received radio packets and signal strength.
POWER (Green)	Indicates that the device has been powered on and bit rates are established.

Table 2: LEDs on the Kvaser Air Bridge 'one-to-any'.



Before power is indicated, the LEDs briefly perform a LED test, indicate states related to the establishment of the radio link and indicate state of the autobaud detection, if enabled.



Figure 3: LEDs on the Kvaser Air Bridge.

3.5 Commissioning

The Kvaser Air Bridge 'one-to-any' builds on a role-based hierarchy to provide synchronization and pairing of Kvaser Air Bridge 'one-to-any' devices. All Kvaser Air Bridge 'one-to-any' devices have the possibility of assuming one of two roles, i.e. acting as a Primary device or a Secondary device. By default, all Kvaser Air Bridge 'one-to-any' devices are configured to be Secondary devices.

Before being put into service, the Kvaser Air Bridge 'one-to-any' devices need to be commissioned as either Primary devices or Secondary devices. Kvaser provides a Utility CLI for this purpose. The Utility CLI supports customer specific domain codes to prevent unwanted interference from Kvaser Air Bridge 'one-to-any' devices operated by other organizations. However, all Kvaser Air Bridge 'one-to-any' devices are delivered with default codes that work perfectly well should the user choose not to define the domain codes.

In conjunction with the commissioning, a user can also choose to configure the following operational settings should the application require adaptation to specific characteristics:

- Bit rate
- Custom CAN configuration including silent mode
- Transmit power
- CAN filters

Note: All the settings that are available through the Kvaser Air Bridge Utility CLI are also accessible via the Management Interface and can therefore be configured by any user application developed for that purpose. However, this only applies for the Kvaser Air Bridge 'one-to-any'.

More information can be found below and in the Kvaser Air Bridge Management Interface Description applicable for Kvaser Air Bridge 'one-to-any'.

3.6 Autobaud

The Kvaser Air Bridge devices provides an autobaud feature which is the default setting that will automatically detect and connect to any of the following CAN bus bit rates:

- 1 Mbit/s
- 500 kbit/s
- 250 kbit/s
- 125 kbit/s

The Autobaud Detection is done locally, so a Kvaser Air Bridge can be used to bridge two different CAN bus segments operating at different bit rates. However, the amount of traffic on the networks will determine whether the system designer should allow the networks to be bridged via the Kvaser Air Bridge.



Autobaud is the process of automatically selecting the correct bus parameters for communication on the connected CAN bus based on received CAN traffic. The Autobaud Detection is driven by the reception of CAN messages on the CAN bus segment. This means that there needs to be existing CAN traffic on the network for the Autobaud Detection to work.

If, after 15 seconds of power on, the autobaud detection process has only worked successfully on one of the paired devices the other device will be configured to the same CAN network bit rate. The Autobaud Detection will continue even after 15 seconds, if none of the supported CAN system bit rates have been detected on either of the connected CAN bus segments.



If Kvaser Air Bridge devices are used to bridge two different CAN networks operating at different bit rates, both CAN bus segments need to send messages during the initial 15 seconds after power on in order for the Autobaud Detection to correctly detect the different bit rates.

For any additional/specific bit rate requirement, please contact Kvaser for more information.

3.7 Optional bit rate setting

The bit rate can optionally be set to any of the following bit rate pre-sets:

- 1 Mbit/s
- 500 kbit/s
- 250 kbit/s
- 125 kbit/s
- Autobaud

By default, all Kvaser Air Bridge devices are configured for automatic bit rate selection, autobaud, for which one of the four bit rates above are automatically selected.

Note: In addition to these bit rate pre-sets, the Kvaser Air Bridge 'one-to-any' supports a user configurable bit rate, see Section 3.8 Optional custom CAN configuration.

This configuration is available with the Utility CLI and, for the Kvaser Air Bridge 'one-to-any', also via the Management Interface. For more information, refer to the Kvaser Air Bridge System Integration Guide and the Kvaser Air Bridge Management Interface Description.

Note that the bit rate setting relates to the CAN bus only, and that each Kvaser Air Bridge device therefore can be configured differently.

3.8 Optional custom CAN configuration

The Kvaser Air Bridge 'one-to-any' supports custom CAN configuration, enabling the user to freely select a bit rate up to 1 Mbit/s. Moreover, custom configuration allows users to adjust the sampling criteria and set the Kvaser Air Bridge 'one-to-any' device into silent mode. This setting prevents the device from transmitting on the CAN bus segment, ensuring that it can only wirelessly transfer CAN messages from this CAN bus segment to another CAN bus segment via a paired Kvaser Air Bridge 'one-to-any' device.

The following parameters can be configured.

- CAN bus bit rate (up to 1 Mbit/s)
- Sync Jump Width
- Bit segment 1 (including propagation segment)
- Bit segment 2
- Silent mode

This configuration is available with the Utility CLI and, for the Kvaser Air Bridge 'one-to-any', also via the Management Interface. For more information, refer to the Kvaser Air Bridge User's guide and the Kvaser Air Bridge Management Interface Description.

Note that the Custom CAN configuration relates to the CAN bus only, and that each Kvaser Air Bridge device therefore can be configured differently.

3.9 CAN filters

The Kvaser Air Bridge 'one-to-any' supports the configuration of up to four filters per device. These filters are pass filters, each defined by a filter identifier ID and a filter mask.

This configuration is available only for the Kvaser Air Bridge 'one-to-any', either with the Utility CLI or via the Management Interface. For more information, refer to the Kvaser Air Bridge System Integration Guide and the Kvaser Air Bridge Management Interface Description.

3.10 Pairing

A Kvaser Air Bridge 'one-to-any' device commissioned as Primary device can be paired with any Kvaser Air Bridge 'one-to-any' device commissioned as Secondary device, if it is powered on and within radio coverage and hence can be discovered by the Kvaser Air Bridge 'one-to-any' Primary device. Normally, this discovery and pairing is managed over the CAN bus using dedicated CAN messages. The Primary device starts by prompting all Secondary devices to report their presence, while reporting all present Secondary devices and their unique identifiers (same as serial numbers) to the application (client). After a short time, the application can request that the Primary device is paired with a specific Secondary device, using its unique identifier.

A Kvaser Air Bridge 'one-to-any' Primary device can also be paired with a preferred Kvaser Air Bridge 'one-to-any' Secondary device without this being powered and within coverage. This pairing can be performed through the management protocol. The Kvaser Air Bridge 'one-to-any' can be preconfigured as a pair of devices and as such it will only need to be configured once.

More information can be found in the Kvaser Air Bridge Management Interface Description.

4 Appendices

In this section you will find technical information about the Kvaser Air Bridge M12.

4.1 Technical data

In Table 3 below you will find the Kvaser Air Bridge M12's technical specifications. The physical dimensions are given in Figure 4 on Page 16.

CAN Channels	1
CAN Transceivers	TJA1051T (Compliant with ISO 11898-2)
CAN Controller	Built into the processor
CAN Bit Rate	1 Mbit/s, 500 kbit/s, 250 kbit/s, and 125 kbit/s
Autobaud ¹	Yes
Configurable bit rate	Yes
Custom CAN configuration	Yes
User defined Custom CAN parameters ⁴	Bit rate, Sync Jump Width and Bit segments
Message Rate, CAN 2.0A (11-bit ID) ²	2x2100 messages/s
Message Rate, CAN 2.0B (29-bit ID) ²	2x1680 messages/s
Message transfer capacity ³	Corresponding to 100% bus load for both directions at 250 kbit/s bit rate
Silent mode	Yes
CAN filters	Up to four pass filters per device ⁵
Message Transfer Latency	Typically 2.5-7.5 ms
Connection time from power up	Normally less than 1 s
Reconnection time	Normally less than 200 ms
Wireless Communication	Frequency Hopping Spread Spectrum (FHSS) with Gaussian Frequency-Shift Keying (GFSK) modulation
Frequency Range	2400 MHz to 2483.5 MHz (2.4 GHz band)
Antenna Output Power	Max 18 dBm
Power Supply	9-36 VDC
Power Consumption	Typically 2 W
Current Consumption (at 9 VDC)	Typically 220 mA
Weight	85 g
IP Rating Housing	IP65
IP Rating CAN connector	IP67 Mated
Operating Temperature	-40 °C to +70 °C

Table 3: Technical Specifications.

4.2 Physical dimensions

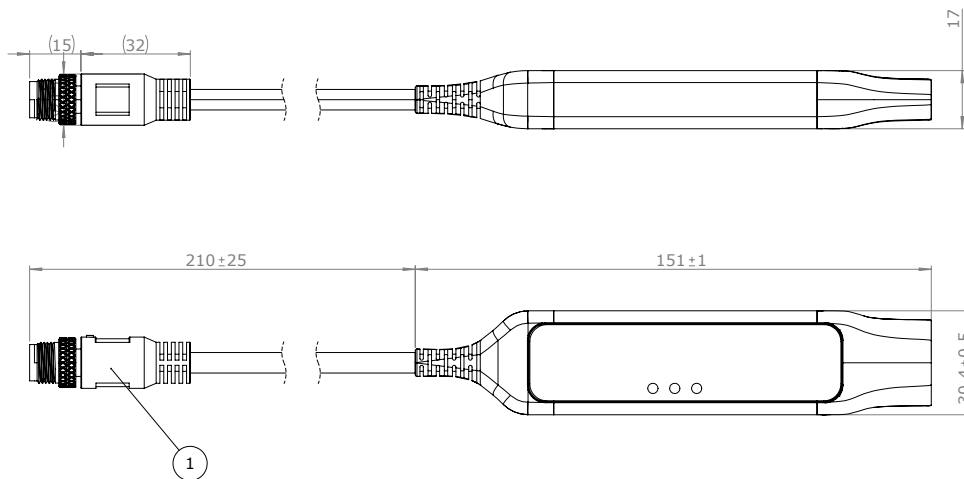

Figure 4: Physical dimensions of the Kvaser Air Bridge M12

4.3 CAN Connectors

Kvaser Air Bridge M12 devices that use the 5-pole male M12 connector have the pinning described in Table 4 on Page 17.

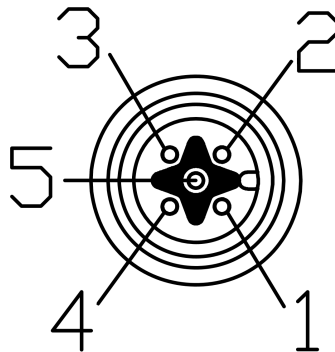

Figure 5: 5-pole male M12 Connector

¹Automatic establishment upon start-up. See Section 3.6, Autobaud, on Page 12 for more information.

²Maximum message rate in both directions for eight byte payload. Refer to "Kvaser Air Bridge System Integration Guide" for more information.

³Recommended maximum load is 80%. Refer to "Kvaser Air Bridge System Integration Guide" for more information.

⁴Refer to "Kvaser Air Bridge System Integration Guide" for more information.

⁵Refer to "Kvaser Air Bridge System Integration Guide" for more information.

M12 pin number	Function
1	Shield
2	Power supply to the device
3	GND
4	CAN_H
5	CAN_L

Table 4: 5-pole M12 pin configuration

4.4 CAN bus termination

Every CAN bus must be terminated with a 120 Ohm resistor at each end of the bus. The Kvaser Air Bridge M12 does not contain any CAN bus termination, because their inclusion could cause severe disturbance in a system which is already correctly terminated.

For laboratory or testing use, the exact value of the termination resistors is not always critical. Sometimes a single terminator is sufficient. For production, proper termination is essential. If you see error frames on the bus, you should check the termination.



To save yourself a lot of trouble, always terminate the CAN bus properly.

4.5 Kvaser Air Bridge Utility CLI

General

The Kvaser Air Bridge Utility CLI is a PC based tool to be employed by Kvaser Air Bridge users for firmware upgrade, commissioning and configuration of Kvaser Air Bridge devices. The Kvaser Air Bridge Utility CLI contains all functionality for this purpose and the firmware distribution is embedded into the Kvaser Air Bridge Utility CLI.

The Utility CLI is a Command Line Interface that enabled control and configuration of parameters based on arguments followed by values. The arguments with values can be written in any order. Arguments are available in shortform (one hyphen in some cases followed by a letter) or in full (two hyphens in some cases followed by a complete word). The connect command to CAN bus 0 can e.g. be written as:

- -c -ch 0
- –connect –channel 0

Note: The verbosity of the Utility CLI can be increased by attaching the argument "-v" with the desired verbosity level. For more information, see the help information in the utility.

Note also that even though the configuration is described in steps below, the Utility CLI allows multiple arguments to be written on one command line. Configuration of a primary device with 250 kbit/s bit rate directly followed by a "list parameter" command is e.g. written as:

```
File_location > airbridge-utility-cli.exe -ch 0 -c -D -SRFR P -SAB 250 -LP
```

In this case, all the device's parameters are listed directly after the command is sent while the power supply to the Kvaser Air Bridge 'one-to-any' device must be cycled before the configurations take effect. In the example above, the "list parameters" command (-LP) will initiate an immediate print of all configured parameters even without power having been cycled. After the power is cycled, the device will have the configured parameters that were printed, in this case including Primary role and 250 kbit/s bit rate.

The Kvaser Air Bridge Utility CLI is available on the Kvaser web site in the Download section and can be installed on a regular Windows PC.

A standard Kvaser interface is required to employ the Kvaser Air Bridge Utility CLI. The Kvaser Air Bridge Utility CLI is supported by the following interfaces:

Interface	Product Number
Kvaser Leaf v3	73-30130-01424-4
Kvaser Leaf Light v2	73-30130-00685-0
Kvaser U100	73-30130-01173-1
Kvaser USBcan Light 2xHS	73-30130-00714-7
Kvaser Memorator Pro 2xHS v2	73-30130-00819-9

Table 5: Kvaser interfaces which the Kvaser Air Bridge Utility CLI is supported by.

Installation

The installation should be performed as follows:

1. Install the Kvaser's SDK and Device guide driver, which can be downloaded from the Kvaser web site.
2. Copy the Kvaser Air Bridge Utility CLI file (`airbridge-utility-cli.exe`) to a file location according to own preference.
3. Install external dependencies from Microsoft:
https://mpvci.b-cdn.net/MPVCI_2.7_setup.exe
4. Start the command window by clicking on the window's icon and type 'cmd' followed by ENTER.
5. Navigate to the preferred file location using appropriate commands, e.g:

```
cd Downloads
```

6. Check that the Utility CLI file (`airbridge-utility-cli.exe`) is in the location (example: `C:\Users\AirBridgeUser\Downloads`) with the 'dir' command:

```
File_location > dir
```

7. The installation can e.g. be checked with the following command:

```
File_location > airbridge-utility-cli.exe -h -v 3
```

8. The Utility CLI will then respond with a general explanation of commands and parameters.

Preparations

The following is required to use the Kvaser Air Bridge Utility CLI:

- The Kvaser Air Bridge devices to be connected.
- A Kvaser interface (a list of interfaces that support Kvaser Air Bridge is given above).
- CAN bus wiring that connects the Kvaser Interface with the Kvaser Air Bridge M12.
- Correct termination of the CAN bus wiring (see Section 4.4, CAN bus termination, on Page 17) and power to the Kvaser Air Bridge.

Preparation of the physical installation for commissioning and firmware upgrade is performed in the following steps:

1. Connect the Kvaser interface (from the list above, e.g. Leaf v3) securely to the Kvaser Air Bridge 'one-to-any' device, making sure that the devices cannot be accidentally disconnected from each other.
2. Apply power to the Kvaser Air Bridge 'one-to-any'. The device will perform the start-up test lighting up each of the three LEDs and then ending with one lit green LED.

Note: It is important that the CAN bus segment, i.e. connection between Kvaser interface and the Kvaser Air Bridge 'one-to-any' is properly terminated.

Commissioning of role (required)

Prepare the physical installation according to the instructions above. Thereafter, perform the commissioning of role according to the following:

1. Switch OFF the power to the Kvaser Air Bridge (the power only)
2. Configure the device's role using **one** of the following commands followed by ENTER:

```
File_location > airbridge-utility-cli.exe -ch 0 -c -D -SRFR P
```

```
File_location > airbridge-utility-cli.exe -ch 0 -c -D -SRFR S
```

A 'P' will commission the device to the role Primary device whereas a 'S' will commission the device to the role Secondary device.

3. Switch ON the power to the Kvaser Air Bridge (the power only). When performed in the correct order the utility will display "Utility connected!" followed by various information.
4. Switch OFF the power to the Kvaser Air Bridge (the power only).

Note: All Kvaser Air Bridge 'one-to-any' devices are factory configured as Secondary devices.

Commissioning of pairing codes (recommended)

Prepare the physical installation according to the instructions above. Thereafter, perform the commissioning of pairing codes according to the following:

1. Switch OFF the power to the Kvaser Air Bridge (the power only)
2. Configure the device's pairing codes by entering their seeds using the following commands and then ENTER:

```
File_location > airbridge-utility-cli.exe -ch 0 -c -D --Set_RF_Primary_Seed xxxx
```

```
File_location > airbridge-utility-cli.exe -ch 0 -c -D --Set_RF_Secondary_Seed yyyy
```

Where 'xxxx' and 'yyyy' represent user specific seeds for the generation of codes to protect the discovery and pairing procedures.

3. Switch ON the power to the Kvaser Air Bridge (the power only). When performed in the correct order the utility will display "Utility connected!" followed by various information.
4. Switch OFF the power to the Kvaser Air Bridge (the power only)

Note: The pairing codes are internally generated from the entered seeds.

Configuration of CAN bus bit rate / Custom CAN configuration (recommended)

Prepare the physical installation according to the instructions above. Thereafter, perform the configuration of CAN bus bit rates according to the following:

1. Switch OFF the power to the Kvaser Air Bridge (the power only).
2. Optional: Enter a Custom CAN configuration using the following command followed by ENTER:

```
File_location > airbridge-utility-cli.exe -ch 0 -c -D \  
--Set_APP_Bitrate C --Set_APP_CAN_PARAMS 105263 11 7 2 0
```

This sets a baudrate of 105263 bps, Tseg1 of 11, Tseg2 of 7, Sync Jump Width of 2, and silent mode off (0).

Note: The resulting bit rate is internally calculated based on desired bit rate and bit segment values.

3. Configure the device's CAN bus bit rate by the following commands followed by ENTER:

```
File_location > airbridge-utility-cli.exe -ch 0 -c -D -SAB 125  
File_location > airbridge-utility-cli.exe -ch 0 -c -D -SAB 250  
File_location > airbridge-utility-cli.exe -ch 0 -c -D -SAB 500  
File_location > airbridge-utility-cli.exe -ch 0 -c -D -SAB 1000  
File_location > airbridge-utility-cli.exe -ch 0 -c -D -SAB A  
File_location > airbridge-utility-cli.exe -ch 0 -c -D -SAB C
```

Note: The last parameter (125, 250, 500, 1000, C and A) represent the CAN bus bit rate in kbit/s where an 'A' represents automatic bit rate adaption to one of the four bit rate pre-sets and a 'C' represents the Custom CAN configuration (optionally configured in step 2 above). If this has not been configured, the 1000 kbit/s bit rate pre-set will be selected.

4. Switch ON the power to the Kvaser Air Bridge (the power only). When performed in the correct order the utility will display "Utility connected!" followed by various information.
5. Switch OFF the power to the Kvaser Air Bridge (the power only).

Checking the Commissioning and Configuration (recommended)

Prepare the physical installation according to the instructions above. Check the commissioned and configured parameters according to the following:

1. Switch OFF the power to the Kvaser Air Bridge (the power only).
2. Check the commissioning and configuration by the following commands followed by ENTER:

```
File_location > airbridge-utility-cli.exe -ch 0 -c -D -LP
```

3. Switch ON the power to the Kvaser Air Bridge (the power only). When performed in the correct order the utility will display "Utility connected!" followed by various information.
4. Switch OFF the power to the Kvaser Air Bridge (the power only).

Note: For confidentiality reasons, the Utility's response to this "List Parameter" command will never show the entered seeds (primary seed and secondary seed).

Firmware upgrade

Prepare the physical installation as follows:

1. Connect the Kvaser interface securely to the Kvaser Air Bridge Light device, making sure that the devices cannot be accidentally disconnected from each other.
2. Initiate the firmware upgrade using the following command followed by ENTER:

```
File_location > airbridge-utility-cli.exe -ch 0 -c --upgrade
```

3. Apply power to the Kvaser Air Bridge. The device will perform the start-up test lighting up each of the three LEDs and then ending with a lit green LED.

Note: The power supply to the Kvaser Air Bridge must be cycled once before the configuration takes effect.

5 Safety Instructions

5.1 Intended Use

The Kvaser Air Bridge M12 is intended for connection of two CAN bus segments in a fixed installation.

5.2 Usage Warning



CAUTION: THE SURFACE OF THIS DEVICE MAY BECOME HOT IF IT IS EXPOSED TO FOR EXAMPLE RADIATION FROM THE SUN.



WARNING FOR ALL USERS

WARNING! - YOUR USE OF THIS DEVICE MUST BE DONE WITH CAUTION AND A FULL UNDERSTANDING OF THE RISKS!

THIS WARNING IS PRESENTED TO INFORM YOU THAT THE OPERATION OF THIS DEVICE MAY BE DANGEROUS. YOUR ACTIONS CAN INFLUENCE THE BEHAVIOR OF A CAN-BASED DISTRIBUTED EMBEDDED SYSTEM, AND DEPENDING ON THE APPLICATION, THE CONSEQUENCES OF YOUR IMPROPER ACTIONS COULD CAUSE SERIOUS OPERATIONAL MALFUNCTION, LOSS OF INFORMATION, DAMAGE TO EQUIPMENT, AND PHYSICAL INJURY TO YOURSELF AND OTHERS. A POTENTIALLY HAZARDOUS OPERATING CONDITION IS PRESENT WHEN THE FOLLOWING TWO CONDITIONS ARE CONCURRENTLY TRUE: THE PRODUCT IS PHYSICALLY INTERCONNECTED TO A REAL DISTRIBUTED EMBEDDED SYSTEM; AND THE FUNCTIONS AND OPERATIONS OF THE REAL DISTRIBUTED EMBEDDED SYSTEM ARE CONTROLLABLE OR INFLUENCED BY THE USE OF THE CAN NETWORK. A POTENTIALLY HAZARDOUS OPERATING CONDITION MAY RESULT FROM THE ACTIVITY OR NON-ACTIVITY OF SOME DISTRIBUTED EMBEDDED SYSTEM FUNCTIONS AND OPERATIONS, WHICH MAY RESULT IN SERIOUS PHYSICAL HARM OR DEATH OR CAUSE DAMAGE TO EQUIPMENT, DEVICES, OR THE SURROUNDING ENVIRONMENT.

WITH THIS DEVICE, YOU MAY POTENTIALLY:

- CAUSE A CHANGE IN THE OPERATION OF THE SYSTEM, MODULE, DEVICE, CIRCUIT, OR OUTPUT.
- TURN ON OR ACTIVATE A MODULE, DEVICE, CIRCUIT, OUTPUT, OR FUNCTION.
- TURN OFF OR DEACTIVATE A MODULE, DEVICE, CIRCUIT, OUTPUT, OR FUNCTION.
- INHIBIT, TURN OFF, OR DEACTIVATE NORMAL OPERATION.
- MODIFY THE BEHAVIOR OF A DISTRIBUTED PRODUCT.
- ACTIVATE AN UNINTENDED OPERATION.
- PLACE THE SYSTEM, MODULE, DEVICE, CIRCUIT, OR OUTPUT INTO AN UNINTENDED MODE.

ONLY THOSE PERSONS WHO:

(A) ARE PROPERLY TRAINED AND QUALIFIED WITH RESPECT TO THE USE OF THE DEVICE,

(B) UNDERSTAND THE WARNINGS ABOVE, AND

(C) UNDERSTAND HOW THIS DEVICE INTERACTS WITH AND IMPACTS THE FUNCTION AND SAFETY OF OTHER PRODUCTS IN A DISTRIBUTED SYSTEM AND THE APPLICATION FOR WHICH THIS DEVICE WILL BE APPLIED, MAY USE THE DEVICE.

PLEASE NOTE THAT YOU CAN INTEGRATE THIS PRODUCT AS A SUBSYSTEM INTO HIGHER-LEVEL SYSTEMS. IN CASE YOU DO SO, KVASER AB HEREBY DECLARES THAT KVASER AB'S WARRANTY SHALL BE LIMITED TO THE CORRECTION OF DEFECTS, AND KVASER AB HEREBY EXPRESSLY DISCLAIMS ANY LIABILITY OVER AND ABOVE THE REFUNDING OF THE PRICE PAID FOR THIS DEVICE, SINCE KVASER AB DOES NOT HAVE ANY INFLUENCE ON THE IMPLEMENTATIONS OF THE HIGHER-LEVEL SYSTEM, WHICH MAY BE DEFECTIVE.

6 Disposal and Recycling Information



When this product reaches its end of life, please dispose of it according to your local environmental laws and guidelines.

For information about Kvaser's recycling programs, visit:
<https://www.kvaser.com/en/kvaser/recycling-policy.html>

7 Legal acknowledgements

7.1 EU Regulatory Compliance



EU Declaration of Conformity (DoC)

We

Company Name:	Kvaser AB	City:	Mölndal
Postal address:	Aminogatan 25	Telephone number:	+46 31 886344
Postcode:	431 53	E-mail address:	sales@kvaser.com

declare that the DoC is issued under our sole responsibility and belongs to the following product:

Product: Kvaser Air Bridge M12

Object of the declaration (identification of apparatus allowing traceability):

Product: Kvaser Air Bridge M12

Type: 73-30130-01494-7

The object of the declaration described above is in conformity with the relevant Union harmonisation legislation:

Radio Equipment Directive (RED) 2014/53/EU (Art. 3.1a, 3.1b and 3.2)

RoHS recast Directive 2011/65/EU (Art. 4.1)

The following harmonised standards and technical specifications have been applied

(title, date of standard/specification):

EN 203 367 (2016-03 (1.1.0))	EN 300 328 (2016-11 (2.1.1))
EN 301 489-1 (2016-11 (2.1.1))	EN 301 489-17 (2016 (3.1.1))
EN 55032 (2015 + A11:2020)	EN 62 368-1 (2014 + AC:2015)
EN 50581 (2012)	

Signed for and on behalf of:

Mölndal

2024-02-12

Place of issue

Date of issue

Kent Lennartsson, Research Manager

7.2 FCC Regulatory Compliance



Federal Communications Commission (FCC) Compliance Information Statement

IDENTIFICATION OBJECT:

Product: Kvaser Air Bridge M12

Type: 73-30130-01494-7

APPLICABLE COMPLIANCE STATEMENTS:

CFR Title 47 Part 15 §15.107, §15.109

This device complies with part 15 of the FCC Rules.

Operation is subject to the following two conditions:

- (1) This device may not cause harmful interference, and
- (2) this device must accept any interference received, including interference that may cause undesired operation.

RESPONSIBLE PARTY (IN USA) NAME:

Kvaser Inc.

23881 Via Fabricante, Suite 503

Mission Viejo, CA 92691

Internet contact: support@kvaser.com

7.3 Patents, Copyrights and Trademarks

All trademarks are the property of their respective owner. Windows is a registered trademark of Microsoft Corporation in the United States and other countries.

Adobe, the Adobe logo, and Reader are either registered trademarks or trademarks of Adobe Systems Incorporated in the United States and/or other countries.

DeviceNet is a trademark of Open DeviceNet Vendor Association, Inc.

NMEA 2000 is the registered trademark of the National Marine Electronics Association, Inc.

For information about Kvaser related CAN patents, see www.kvaser.com/patent.

The products described in this document are protected by U.S. patent 5,696,911.

8 Document Revision History

Version history for document UG_98297_air_bridge_m12:

Revision	Date	Changes
1.0	2024-02-12	Initial version.
1.1	2024-05-07	Updated Kvaser logo, pictures, the major features list and technical data table. Minor textual changes.
1.2	2024-09-06	Updated the major features list, technical data table and instructions for the Kvaser Air Bridge Utility CLI. Minor textual changes.